

# Operating instructions

for combined refrigerator-freezer with electronic control system, NoFrost

**GB**

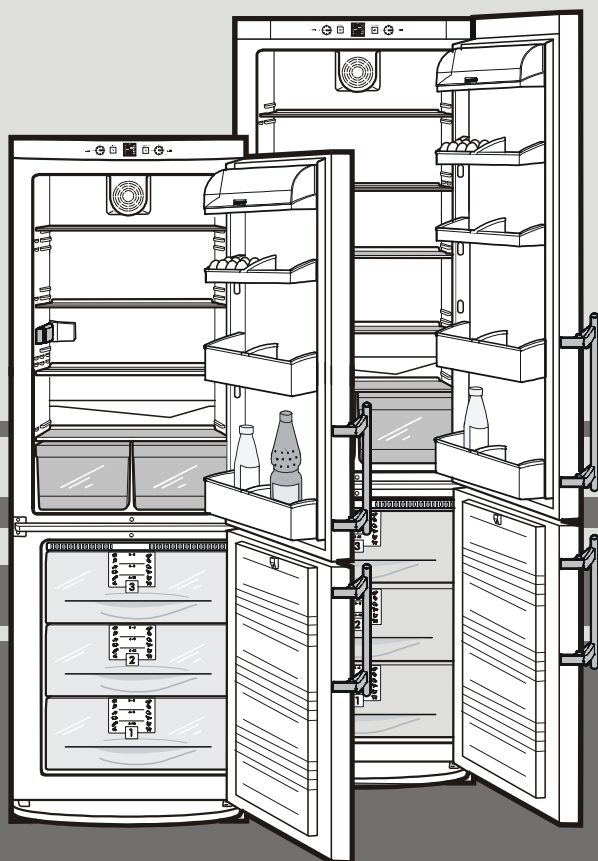

**7082 224-00**

CN/CNa...3 1004

**LIEBHERR**

## Operating and control elements, fig. A1

### Freezer compartment

- ① Main On/Off control for the complete appliance (refrigerator and freezer compartment), with temperature control for freezer compartment
- ② SuperFrost button with indicator light for activated function
- ③ Temperature setting display for freezing temperature
- ④ Audible warning On/Off button, with indicator light for too high temperature in freezer compartment

### Refrigerator compartment

- ⑤ On/Off switch and temperature control for refrigerator compartment
- ⑥ Temperature setting display for refrigerating temperature

### Control setting for temperature

1<sup>st</sup> dot = warm  
max. = cold

- Recommended control setting for:  
Refrigerator compartment: 5 °C, freezer compartment: -18 °C

### SuperFrost

For fast freezing of fresh food.

- Press the SuperFrost button ② briefly, so that it lights up.
- Wait approx. 6 - 24 hours.
- Place the fresh food in the drawers.
- The SuperFrost function **switches off automatically** after about 65 hours.

### Type/Data plate, fig. A2

- ① Type designation
- ② Service number
- ③ Appliance number
- ④ Freezing capacity in kg/24 hours

## Description of appliance and equipment, fig. A

### Refrigerator, approx. 5°C

Transport grips  
Operating and control elements  
Butter and cheese compartment  
Fan with switch ⑦, for re-circulated air cooling

Egg tray\*  
Sectioned shelf for tall containers, adjustable\* storage shelves  
Adjustable bottle/can holder\*  
Adjustable door storage rack\*  
Interior light  
Defrost drain (refrigerator)

Coldest area of the refrigerator compartment, suitable for cold-sensitive and highly perishable foods  
Bins for vegetables, salad and fruit

Type/Data plate  
Door rack for large bottles and drinks

### Freezer, approx. -18°C

Freezer tray\*, cold-storage accumulator\*, ice-cube tray\*  
VarioSpace  
Information system\*

Drawers with transparent front

Adjustable-height feet, transport grips, transport castors at back

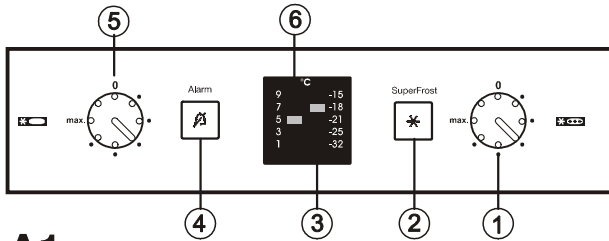

A1

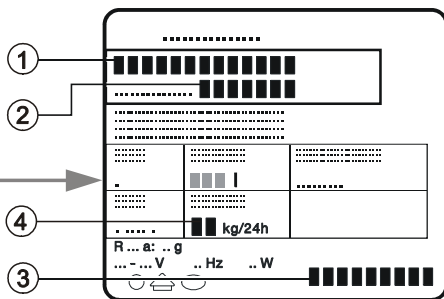

A2

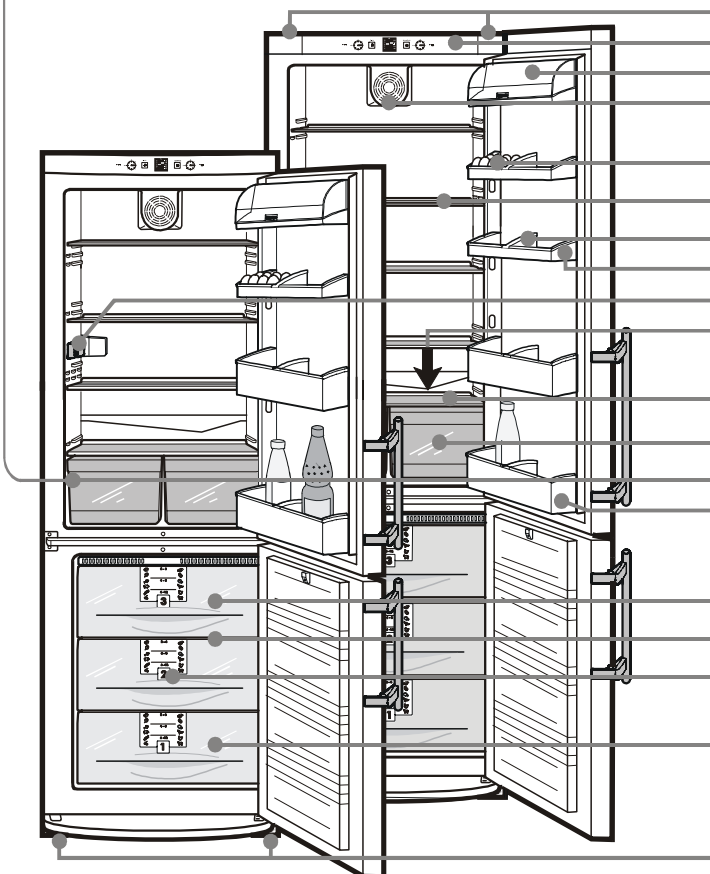

A

Congratulations on your purchase. In choosing this appliance you have opted for all the benefits of state-of-the-art refrigeration technology, guaranteeing you top quality, a long life span and excellent reliability.

The features on your appliance have been designed to ensure maximum convenience - day in, day out. This appliance has been manufactured with recyclable materials using an environmentally friendly process, so together you and we are making an active contribution to the preservation of our environment. To get to know all the benefits of your new appliance, please read the information contained in these operating instructions carefully.

We wish you much pleasure with your new appliance.

Keep these operating instructions in a safe place and pass them on to the next owner, where applicable. The instruction is valid for several models, deviations are therefore possible.

## Contents

<b>Operating instructions</b>	<b>Page</b>
The appliance at a glance .....	12
Contents .....	13
Safety regulations .....	13
Notes on energy saving .....	13
Safety instructions and warnings .....	14
Disposal notes .....	14
Setting up .....	14
Connecting to the mains .....	14
Operation and control elements .....	15
Switching the appliance on and off .....	15
Setting the temperature .....	15
SuperFrost .....	15
Temperature setting display .....	15
Audible warning signal, red visual warning light .....	15
Refrigerating with fan .....	15
Refrigerator compartment .....	16
Arranging food in the refrigerator .....	16
Changing shelf arrangement .....	16
Interior light .....	16
Freezer compartment .....	17
Freezing with SuperFrost .....	17
Notes on freezing and storage .....	17
Information System .....	18
Freezer tray .....	18
Cold-storage accumulators .....	18
Making ice-cubes .....	18
Cleaning .....	19
Troubleshooting .....	19
Customer service and type plate .....	19
<b>Instructions for installation and modification</b>	
External dimensions of the appliance .....	20
Changing over door hinges .....	20
Insertion into row of kitchen units .....	20

## Safety regulations

- The appliance is designed to cool, freeze and store food and to make ice. It is designed as a household appliance. Perfect functioning cannot be guaranteed for any other use.
- The appliance is set to operate within specific ambient temperature limits according to its climate rating. These temperature limits should not be exceeded. The correct climate rating for your appliance is indicated on the type plate. This is explained as follows:

Climate class	designed for ambient temperatures of
SN	+10°C to +32°C
N	+16°C to +32°C
ST	+18°C to +38°C
T	+18°C to +43°C

- The refrigerant circuit has been tested for leaks.
- The appliance complies with current safety regulations and EC directives 73/23/EEC and 89/336/EEC.

## Notes on energy saving

- Ensure that there is adequate space around the appliance for ventilation and air extraction.
- Avoid keeping the door open for too long.
- Store food logically. Do not exceed the storage period specified.
- Keep all food properly packed and covered so as to avoid its frosting up on the outside.
- Always allow hot food to cool to room temperature before placing in the appliance.
- Defrost frozen food in the refrigerator.
- Keep the appliance door shut in the event of a breakdown. This will delay the cold loss. The quality of the frozen goods is maintained longer.

# Safety instructions and warnings

## Disposal notes

The **packaging** is designed to protect the appliance and individual components during transport and is made of recyclable materials.



- Corrugated board/board
- Moulded polystyrene (foamed, CFC-free polystyrene)
- Polythene bags and sheets
- Polypropylene straps

- **Keep packaging materials away from children - polythene sheets and bags can suffocate!**
- Please return the packaging material to your nearest official collection point so that the various materials can be reused or recycled as far as possible.

## Your old appliance:

This contains some reusable materials and should not simply be disposed of with household or bulk refuse.

- Disable discarded appliances immediately by removing the plug and cutting through the connection cable. 
- **Remove spring or bolt lock so that children cannot lock themselves in when playing - they will suffocate.**
- Ensure that the refrigerant circuit is not damaged before the appliance that is no longer needed is taken away for disposal. In this way the refrigerant or oil will not escape into the environment.
- Exact details of the refrigerant used are given on the type plate, heat insulator is PU with pentane.
- Information on collection dates or collection points can be obtained from the waste disposal authorities or local council.



## Technical safety

- To prevent injury or damage to the unit, the appliance should only be transported wrapped and set up by two people. 
- The refrigerant R 600a is environmentally friendly but flammable.
- Do not damage the refrigerant circuit pipes. Splashes of refrigerant can harm your eyes or ignite.
- If refrigerant escapes, remove all naked flames or sources of ignition in the vicinity of the leak, disconnect the appliance from the mains and ventilate the area well.
- In the event that the appliance is damaged, contact the supplier immediately before connecting to the mains.
- To guarantee safe operation, ensure that the appliance is set up and connected as described in these operating instructions.
- In the event of a fault, disconnect appliance from mains: pull out the plug (do not pull on connection cable) or trip or turn out fuse.
- **Any repairs and work on the appliance should only be carried out by the customer service department, as unauthorised work could prove highly dangerous for the user.** The same applies to changing the mains power cable.

## Safety during use

- Do not store any explosive materials or spray cans with flammable propellants in the appliance, such as butane, propane, pentane etc. Electrical components might cause leaking gas to ignite. You can identify such sprays by the printed contents or a flame symbol. 
- Only store high-percentage alcohol in tightly sealed, upright containers.
- Do not allow naked flames or ignition sources to enter the appliance.
- Do not use electrical appliances inside the appliance (e.g. steam cleaners, heaters).
- Do not stand on the plinth, drawers or doors or use them to support anything else.
- The appliance is not intended for use by young children or infirm persons without supervision.
- Do not let children play with the appliance, e.g. do not allow them to sit in the drawers or swing on the door.
- Do not eat ice-cream, particularly ice lollies or ice-cubes, immediately after taking them from the freezer compartment as there is a risk of "burning" because of the very cold temperatures.
- Do not consume food which has been stored for too long, as it could cause food poisoning.

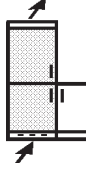
## Setting up

- When setting up/fitting ensure that the refrigerant circuit pipes are not damaged.
- Standard EN 378 specifies that the room in which you install your appliance must have a volume of 1 m<sup>3</sup> per 8 g of R 600a refrigerant used in the appliance, so as to avoid the formation of inflammable gas/air mixtures in the room where the appliance is located in the event of a leak in the refrigerant circuit. The quantity of refrigerant is given on the type plate in the interior of the appliance.
- Avoid positioning in direct sunlight or next to an oven, radiator or similar, in damp locations or near spraying water.
- Once in position, use the 10 spanner provided to adjust the feet so that the appliance is level and does not wobble. 
- **The ventilation grilles should not be obstructed. Always ensure that there is good ventilation and that the outward flowing air is able to escape.** More information can be found in the installation and modification instructions. 
- Do not place heat-emitting appliances, e.g. microwave oven, toaster, etc., on top of the refrigerator or freezer.
- When you open the door for the first time, the handle switches from the transport position to the operating position; you will hear a soft click. 
- Remove all transportation safety components:
  - Remove sticky tape or spacers\* from shelves and insert shelves in the required position.
  - Remove all protective film: from the decorative trims, front walls and side walls\*.

## Connecting to the mains

### Power supply (AC) and voltage

at the operating point must comply with the details on the type plate, which is located inside the appliance on the left, fig. A. 

- **Connect the appliance with a properly earthed fused plug and socket only.**
- The socket must be fused with a 10 A fuse or higher, it must be away from the rear of the appliance and must be easily accessible.
- *Do not*
  - connect to stand-alone inverters,
  - operate with so-called energy-saving plugs - this can damage the electronic system,
  - connect to the supply with other equipment using an extension cable - risk of overheating.
- When removing the mains cable from the back of the appliance, remove the **cable holder** so as to avoid vibration noise.

The wires in the mains lead are coloured in accordance with the following code:

green/yellow = earth, blue = neutral, brown = live.

**Warning! This appliance must be earthed.**

### Non-rewireable plugs BS 1363

If this machine or appliance is fitted with a non-rewireable plug, the following information applies: If the socket outlets are not suitable for the plug supplied with this product, it must be cut out and an appropriate plug fitted. The plug cut from the flexible cord should be disposed of and on no account be inserted into a 13 A socket elsewhere in the house (electric shock hazard).

The fuse cover **must** be re-fitted when changing the fuse, and if the fuse cover is lost the plug **must not** be used until a suitable replacement is obtained. The colour of the correct replacement cover is that of the coloured insert in the base of the plug, or the colour that is embossed in words on the base of the plug (as applicable to the design of the plug fitted).

The correct rating of the replacement fuses that are ASTA approved to BS 1362 should be fitted. Replacement fuse covers may be purchased from your local electrical suppliers, electricity showroom or approved service agent.

# Operation and control elements

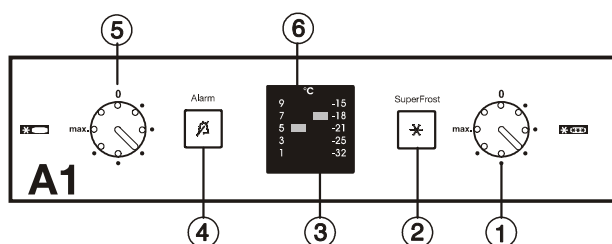

You are advised to clean the appliance before switching it on for the first time (see "Cleaning"). Switch on the appliance approx. 4 hours before loading it with frozen food for the first time. Do not load with frozen food until the red warning light has gone out.

## Switching the appliance on and off

- Fig. A1: With the main On/Off control ① you always switch the complete appliance on or off, freezer and refrigerator compartment.
- **Switching on:** Turn the slot of the temperature control ① for the freezer compartment and ⑤ for the refrigerator compartment with a coin, so that the temperature setting displays ③ and ⑥ flash/light up.
  - The refrigerator compartment is switched on when the temperature setting display ⑥ is lit and the interior light is on.
  - The freezer compartment is switched on when the temperature setting display ③ is lit.
  - The alarm button lights up red until the freezing temperature is low enough; it will then go out. See section "Audible warning signal, red visual warning light" for more information.
- **Switching off the complete appliance:** Turn the slot of the main On/Off control ① with a coin right back to position "0", so that the temperature setting displays are unlit. The refrigerator and freezer compartments are switched off.
- If you want to switch off only the **refrigerator compartment** (freezer compartment remains switched on - advantageous, for example, for holiday periods), turn only the On/Off control ⑤ back to "0", so that the temperature setting display of the fridge compartment ⑥ and the interior light are unlit. The temperature setting display of the freezer compartment ③ must be lit.

## Setting the temperature

- Turn temperature controls ① and ⑤ with a coin until the displays ③ and ⑥ of the required temperatures are lit. The slot positions mean:
 

1 <sup>st</sup> dot	= highest temperature,
	lowest refrigerating capacity
max.	= lowest temperature,
	highest refrigerating capacity

- Recommended temperature setting:
  - For the **refrigerator compartment**: 5 °C
  - For the **freezer compartment**: -18 °C

During setting, the display of the set temperature flashes.

**Note:** Please note that the temperature inside the appliance is affected by the frequency with which the door is opened, how full the appliance is and the room temperature at the place where the appliance is installed.

The control is to be readjusted according to the temperature required.

## SuperFrost ②

Fresh food should be frozen to the core as rapidly as possible. Frozen food can also be given a cold boost. This ensures that the nutritional value, appearance and flavour of the food remain intact.

- The maximum amount of food which can be frozen in 24 hours is shown on the type plate ("Freezing capacity ... kg/24h"). This amount varies according to the model and climate rating.

See section "Freezing with SuperFrost" for more information.

## Temperature setting display

- ③ for freezer compartment      ⑥ for refrigerator compartment
- The lit temperature setting display indicates operation of the appliance.
- Temperature ranges are allocated to the individual displays. They indicate the selected setting of the refrigerating/freezing temperature.

## Audible warning signal, red visual warning light

The audible warning signal and the red visual warning light help you to protect the frozen food and to save energy.

- **The buzzer is switched off** by pressing the audible warning on/off button ④,
  - or automatically when the sufficiently low storage temperature has been reached again.
  - It lights up when the freezer temperature is not low enough (dependent on the temperature setting).
  - At the same time the red lamp of the audible warning on/off button flashes.

This can be caused by

- warm, fresh food being placed in the freezer,
- too much warm air entering the freezer when you repack it or take out frozen food. This temperature fluctuation has no effect on the frozen food.
- When the audible warning on/off button is pressed, the **red visual warning light** switches over from flashing mode to permanently lit. It only goes out when the alarm state is ended and a sufficiently low temperature has been reached. The audible warning signal is now automatically reset.
- In case the SuperFrost button flashes *simultaneously* with a light in the temperature display, there may be a fault. Please contact your customer service centre and inform them of the flashing lights. This will ensure that your appliance can be serviced promptly and accurately.

## Refrigerating with fan\*

for re-circulated air cooling

This achieves a relatively even temperature distribution over all storage levels; all foods are equally cool, at an adjustable temperature. With enforced air circulation, the different temperature ranges prevalent during normal operation no longer exist.

It is generally recommended:

- with high room temperatures (above approx. 30 °C),
- with high humidity, e.g. on summer days.

- **Switching on/off:** Press fan switch ⑦.  
 ⏻ = on, 0 = off.

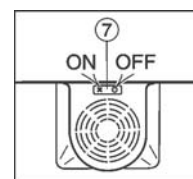

**Note:**

- When the fan is switched on, power consumption is increased.
- To save energy, the fan switches off automatically when the door is open.

## Refrigerator compartment

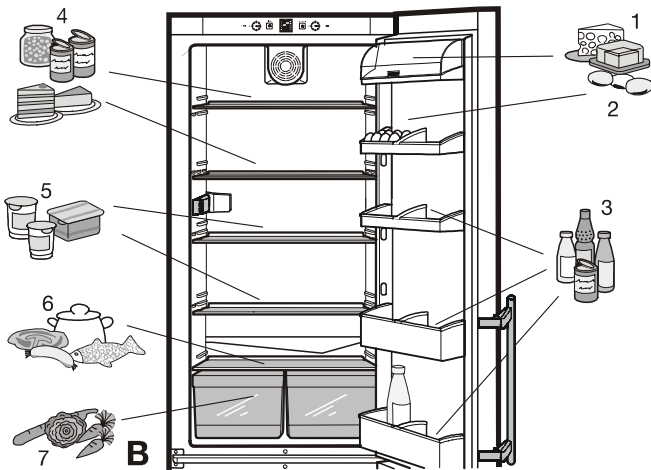

- 1 butter, cheese
- 2 eggs
- 3 cans, drinks, bottles
- 4 preserves
- 5 dairy products, baked goods
- 6 meat and sausage products, fish, pre-cooked meals
- 7 fruit, vegetables, salad

### Arranging food in the refrigerator

Because of the natural circulation of air in the refrigerator compartment, the temperature in different parts of the refrigerator will differ, each area being suitable for different types of food. The coldest temperature is immediately above the vegetable bins and on the rear wall (useful, for example, for sausages and meats); the warmest temperature is at the top front area and in the door (useful, for example, for spreadable butter and cheese).

See fig. B for food storage suggestions.

#### Notes on cooling

- Store food in such a way that the air can circulate well, i.e. do not store goods too close together.
- Food which gives off or absorbs odours and flavours, and liquids should always be stored covered or in closed containers.
- Always store food which gives off or is sensitive to ethylene gases such as fruit, vegetables and salads separately or wrapped in order not to affect their storage life; e.g. do not store tomatoes together with kiwis or cabbage.

### Changing shelf arrangement

You can re-arrange the height of the shelves and door racks as required.

- **Re-positioning the door racks**, fig. C: Slide the door rack up, pull out towards you and replace in reverse order.
- By adjusting the **bottle holder** you can prevent bottles from tipping when the door is opened and closed.
- **Re-positioning the shelves**, fig. D:
  - Lift the shelf, slide forwards and remove. Always insert shelves with the guard bar at the back pointing upwards, otherwise food may freeze onto the rear wall.
  - The glass shelves are fitted with stops to prevent them being pulled out accidentally.
  - If you require space for large bottles and containers
    - Lift the *front half* glass shelf\* slightly and carefully slide under the rear shelf until the pull-out stops lock into position in the recesses, fig. E.

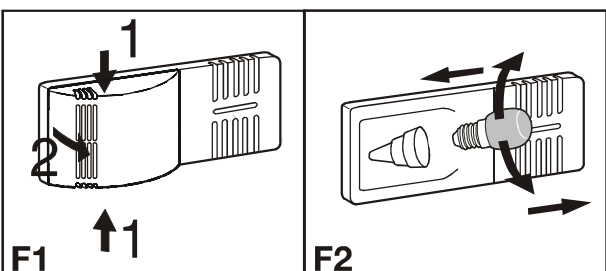
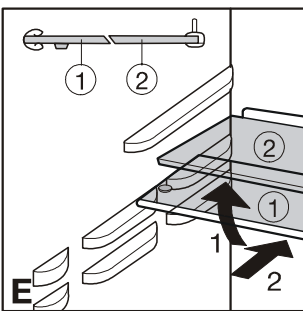
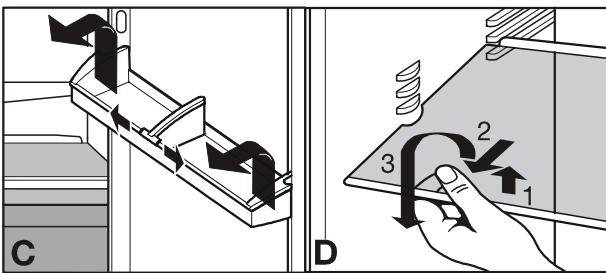

### Interior light

This switches off automatically after the door has been opened for approx. 15 minutes. If it does not switch on when the door is opened briefly, but the temperature display is working, the bulb may be defective.

#### Replacing the bulb:

- **Bulb data:** max. 25 W; current and voltage must agree with the details on the type plate. Only use bulbs of the same size. Bulb fitting: E 14.
- Switch off the appliance. **Disconnect from the mains or remove or unscrew the fuse.**
- Push the sides of the lamp cover fig. F1 together 1, disengage and unhook from rear 2.
- Replace the bulb as in fig. F2.
- Clip the back end of the cover in and clip the sides into place.

# Freezer compartment

## Freezing with SuperFrost

SuperFrost



- Press SuperFrost button ② briefly, so that it is lit. The freezer temperature will decrease and the appliance will switch to the lowest temperature.
- With a small quantity of food to be frozen, wait for approx. 6 hours - normally sufficient, for maximum quantity see type plate under freezing capacity, approx. 24 hours.
- Then place the fresh food inside the freezer, preferably in the top drawers.  
If freezing the *maximum* quantity of food, do *not* use the drawers; instead, place the wrapped food directly on the cooling plates. Once the food is frozen you can load it into the drawers.
- The SuperFrost function switches **off automatically** after about 65 hours. The freezing process is now complete, the **SuperFrost button will go dark**, and the freezer will switch back to normal energy-saving operation.

**Note:** You should *not* switch on the SuperFrost function:

- when placing frozen food in the freezer;
- when freezing up to approx. 2 kg fresh food daily.

## Notes on freezing and storage

- **Items suitable for freezing:** meat, game, poultry, fresh fish, vegetables, fruit, dairy products, bread, baked goods, pre-cooked meals.  
**Not suitable:** lettuce, radishes, grapes, whole apples and pears, fatty meat.
- **Pack frozen food** in standard freezer bags or re-usable plastic, metal or aluminium containers.
- Do not allow fresh food which is to be frozen to come into contact with food already frozen. Always keep packs dry in order to avoid them sticking together.
- Always write the date and contents on the pack and do not exceed the stated storage time for the food. This prevents any risk of quality impairment.
- Pack food which you are freezing yourself in quantities appropriate to your household. To ensure that the food freezes right through quickly, the following quantities should not be exceeded per package:
  - fruit, vegetables: up to 1 kg;
  - meat: up to 2.5 kg.
- Blanch **vegetables** after washing and cutting them. (Add to boiling water for 2-3 minutes, remove and quickly cool down in cold water. If you blanch with a steamer or microwave oven, please observe the relevant operating instructions.)
- Do not salt or season fresh food or blanched vegetables before freezing. Only lightly salt and season other food. Some spices can alter their flavour intensity.
- Do not freeze bottles and cans with carbonated drinks. They may burst. Drinks can be cooled down quickly, but take the bottles out of the freezer compartment after an hour at the most.

- **Storage:** Each drawer and cooling plate can take up to 25 kg frozen food.
- **VarioSpace:** By removing the 2nd and 3rd drawer and the storage tray, you obtain the storage space for bulky goods equivalent to two drawer heights. Poultry, meat, large game pieces and tall baked goods can be frozen whole and further prepared in one piece.
- If you want to use the maximum net capacity, you can remove the drawers and store items directly on the shelves.
  - *Always* leave the bottom drawer in the appliance.
  - If you have removed the top drawer, *do not* cover the fan slits at the back, otherwise the freezer will not work properly.

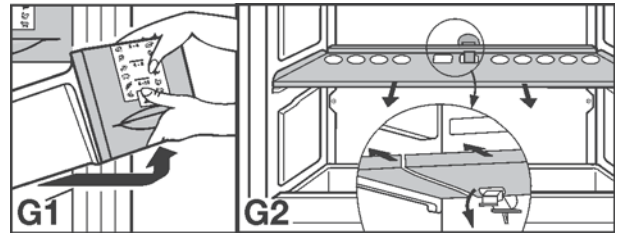

- **Removing drawers**, fig. G1: Pull forward until the drawer stops and lift out.
- **Removing the shelf**, fig. G2: Remove the drawers directly above and below the shelf. Press the hook at the back underneath the shelf downwards and pull the shelf out towards you.  
To insert: slide shelf in and allow to click into place.
- Always store identical food items together to avoid the door being open for unnecessarily long periods and to save energy.
- Do not exceed storage times given.
- **Thawing:** Only take out as much food as is immediately required for thawing. Cook food which has been thawed as quickly as possible.  
Frozen food can be thawed in the following ways:
  - in a conventional or fan oven
  - in a microwave oven
  - at room temperature
  - in the refrigerator: the cold given off by the frozen food is used for cooling the other food.
  - Flat portions of meat or fish can be cooked when partially thawed.
  - Vegetables can be cooked from frozen (in half the normal time).

# Freezer compartment

pre-cooked meals		<b>2 - 6</b>		sausages
ice-cream				bread
fish		<b>4 - 8</b>		mushrooms
pork				game
vegetables		<b>6 - 12</b>		poultry
fruit		<b>2</b>		beef/veal

**G**

## Information system\*

Use frozen food within the recommended period. The numbers between the symbols indicate the storage period in months for different kinds of frozen foods. Storage times given are guide times for food frozen at home. Whether or not the lower or upper value is applicable depends on the food quality and how it was processed prior to freezing. The lower values always apply to food with a high fat content.

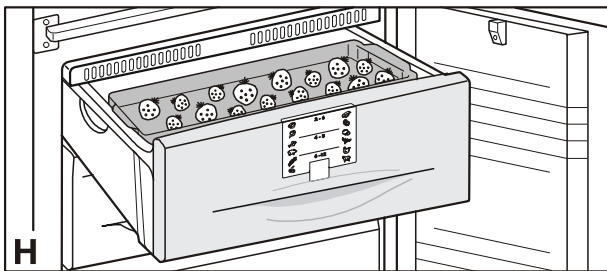

## Freezer tray\*

allows individual freezing of berries, herbs, vegetables and other small frozen goods. It prevents foods freezing together. Items being frozen will largely retain their shape, and it will be easier to remove exactly the right quantity later on.

- Spread the items out loosely on the tray, fig. H.
- Suspend the freezer tray in one of the top drawers. Freeze for 10 to 12 hours, then transfer to a freezer bag or container and put in a drawer.
- To defrost, spread the frozen items out loosely.

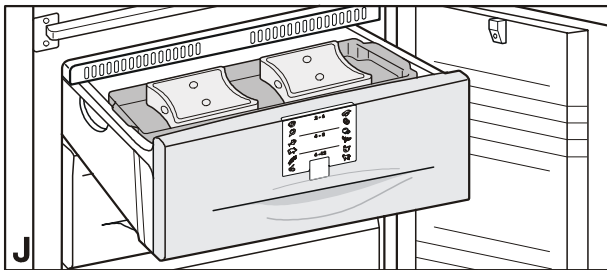

## Cold-storage accumulators\*

These prevent the temperature in the freezer from rising too quickly in the event of a power failure, thus preserving the quality of the food.

- To save space, you can freeze and store the cold-storage accumulators in the freezer tray, fig. J.
- To ensure maximum storage time in the event of a power failure, place the *frozen* cold-storage accumulators in the top freezer drawer on top of the food.

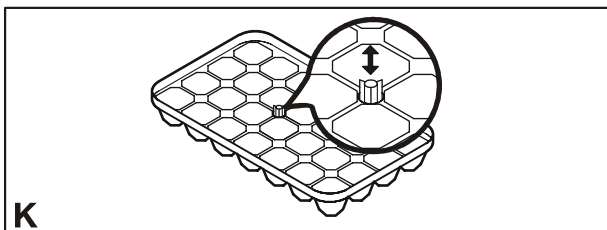

## Making ice-cubes\*

- Press the locking bolt downwards.
- Fill the ice-cube tray with water. Surplus water will flow through the drain hole.
- Push the locking bolt upwards.
- Place the ice-cube tray in the appliance and leave it to freeze.
- The ice-cubes can be removed from the tray by twisting or by holding upside down for a short time under running water.



## Cleaning

### Note on defrosting

The NoFrost system defrosts the appliance **automatically**.

### In the refrigerator compartment

The defrost water is evaporated by the heat from the compressor; drops of water on the rear wall are perfectly normal.

- Ensure that the defrost water can flow freely through the drain hole in the rear wall (arrow in fig.).

### In the freezer compartment

The moisture produced accumulates on the evaporator, is periodically defrosted and evaporates.

Due to the automatic defrosting principle, the freezing compartment remains free of ice at all times, no work or time is required for manual defrosting.

## Cleaning

- **Before cleaning, always switch off the appliance. Disconnect from the mains or unscrew or remove the fuse.**



- Clean the outer walls, inside and equipment by hand with lukewarm water and a little detergent. Because of the risk of injury and damage to the appliance, steam cleaning equipment should not be used.
- We recommend using a soft cloth and an all-purpose cleaner with a neutral pH value. Only use food-safe cleaning and care products in the interior of the appliance.
  - Do not use scouring/abrasive sponges, concentrated cleaning agents and cleaning or chemical solutions containing sand, chloride or acids; they damage the surfaces and can cause corrosion.
  - Do not allow cleaning water to run down the drain gully or to penetrate the ventilation grilles or electrical components. Dry the appliance.
  - Do not damage or remove the type plate on the inside of the appliance - it is important for the customer service department.

- Clean the **drain hole** on the rear wall above the vegetable bins frequently, see **arrow** in figure.

**If necessary, clean with a thin object, e.g. a cotton swab or similar.**

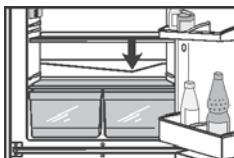

- The dust should be removed from the **refrigeration unit** and heat exchanger - metal grid at the back of the appliance - once a year. Dust deposits increase energy consumption.

- Ensure that none of the wires or other components are dislodged, bent or damaged.

- Then connect/switch on the appliance, and switch on SuperFrost. You can start loading the freezer as soon as the red visual warning light has gone out.



If the appliance is to be **left switched off for any length of time**, empty the appliance, disconnect from the mains, clean as described above and leave the door open so as to avoid odours.

## Troubleshooting

Your appliance is designed and manufactured for a long life span and reliable operation.

If a malfunction nonetheless occurs during operation, check whether it is due to an operating error. Please note that even during the warranty period the resultant servicing costs in this case will have to be borne by the owner.

You may be able to rectify the following faults by checking the possible causes yourself:

### Malfunction Possible cause and remedy

#### Appliance does not work, display is unlit

- Is the appliance switched on properly?
- Is the mains plug properly inserted in the socket?
- Is the socket fuse intact?

#### The interior light does not come on

- Is the refrigerator compartment switched on?
- Has the door been open for more than 15 minutes?
- The bulb is defective. Change the bulb as described in "Interior light".

#### Loud running noise

- Is the appliance standing firmly on the floor, or does the compressor cause nearby items of furniture or objects to vibrate? If necessary, move the appliance slightly, align by adjusting the adjustable feet, or move bottles and containers apart.
- The following are normal: *flow noises*, bubbling or dripping noises, they come from the refrigerant flowing in the refrigerant circuit.

A short *clicking sound*: This will be heard whenever the refrigeration unit (the motor) switches on or off automatically.

*Motor noise*: This will be slightly louder for a brief period when the refrigeration unit switches on.

#### Alarm sounds, red visual warning light button lights up, temperature is not low enough

- Have you put too much fresh food into the freezer *without* activating SuperFrost? (See section "SuperFrost")
- Does the door close properly?
- Is the appliance sufficiently well ventilated? Clear ventilation grilles if necessary.
- Is the ambient temperature too hot? (See section "Safety regulations")
- Has the appliance been opened too often or left open too long?

## Customer service and type plate

If none of the above causes apply and you cannot rectify the fault yourself, or if *more than one* indicator light is *flashing*, please contact your nearest service centre (see attached list).

Inform the service centre of the **type designation** ①, **service number** ② and **appliance number** ③

of the type plate, and **which of the indicator lights** are flashing, so as to ensure rapid, specific service.

The type plate is located inside the freezer compartment on the left-hand side.

Leave the appliance shut until the customer service engineer arrives so as to prevent any further cold loss.

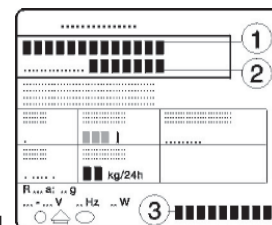

# Instructions for installation and modification

For the **external dimensions of the appliance**, see fig. **S** attached to the rear of the appliance and the table below.

Appliance, gross capacity of models (l) see type plate	Height H (mm)
<b>289</b> (30..)	1625
<b>337</b> (35..)	1806
<b>375</b> (39..)	2000
<b>383</b> (40..)	1982

## Installation instructions

Do not install the appliance side-by-side with another refrigerator or freezer. This is important to prevent condensation and consequential damage from it.

## Changing over door hinges

Fig. **T**. The door hinges can be changed from one side to the other if required:

Only change over door hinges when mains plug is disconnected!

- With the door open, lever out plinth panel ① on the hinge side with a screwdriver and remove from front.
  - Lever out cover ② with a screwdriver. Close door.
  - Unscrew screw M5 ③.
- Pull hinge component ④ with hinge pin ⑤ out from underneath and remove.
  - Open door, lift out at bottom and remove.
  - Pull middle hinge pin ⑥ out from underneath.
  - Tilt out top door and lift off from underneath (with version I, do not lose spacer sleeve ⑨).
- Transfer all hinge components onto the other side:
  - Top: depending on version, proceed as follows:
    - **Version I** (*visible* operating panel): Lever out covers ⑧ with a screwdriver at the front and remove at an angle from below. Remove hinge pin ⑦ and insert on the opposite side. Use the hexagon socket on the open-ended spanner provided (spanner width 5). Fit covers ⑧ again: insert at rear and click into place at front.
    - **Version II** (*concealed* operating panel): Lift up cover ⑧ on handle side, push outwards; lift up cover on hinge side and pull off.
  - Unscrew earthing plate ⑩: first earthing screw ⑫, then inner retaining screw ⑬.
  - Unscrew hinge ⑨: first undo earthing screw ⑫, then retaining screws ⑬. Fit hinge ⑨ to opposite side: for easy assembly, fit hinge from above and first tighten with the upper retaining screw ⑬ M5, then screw ⑬ and finally earthing screw ⑫ M4.
  - Turn earthing plate ⑩ through 180° and screw tight again on the new handle side: first retaining screw ⑬, then earthing screw ⑫.
  - Insert hinge pin ⑦ in the other retaining hole. Use the hexagon socket on the open-ended spanner provided (spanner width 5).
  - Fit covers ⑧ again: insert hinge-side cover by sliding outwards and click into position; insert handle-side cover by sliding inwards and click into position.
- Centre: Change over cover ⑩ with hinge ⑪: unscrew screws, lift off cover ⑩ and hinge ⑪ to the side, turn through 180° and replace on the other side, remove hinge bushing ⑭ and re-insert from top.
- Bottom: Using a screwdriver, remove the spacer ⑬, fig. **T1**, and replace on the other side.
- Re-attach the doors:
  - Remove plugs ⑮ from the door mounting points and replace on the other side.
  - Suspend top door in hinge pin ⑦ (with version I, do not lose spacer sleeve ⑨), close door.
  - Slide middle hinge pin ⑥ into the door mounting from below through the hinge ⑪. Make sure the door is flush with the body of the appliance; adjust if necessary using the slots on the hinge.

- Suspend lower door, close.
- Rotate hinge component ④ by 180°, remove hinge pin ⑤, turn by 180° and replace. Mount both parts in the hinge ⑪: slide the pin into the door mounting through the hinge, tilt in the hinge component, slide up and attach with screw ③.
- Align the door *flush* with the body of the appliance using the slot on the hinge ⑪, then tighten screw ③.
- Attach the plinth panel ① and click into place by pressing.
- With the door open, insert the cover ② in the plinth panel at the front and click into place at the back.
- Transfer\* **door handles** ⑯ and plugs ⑰. With the door open, carefully lift out the pressure plates\* ⑱ at the front and slide away; unscrew handle using a Torx® or Phillips screwdriver\*.
  - Reassemble in reverse order: replace the pressure plates and click into position.

## Insertion into row of kitchen units

Fig. **U**. The appliance can be integrated into the kitchen units. To adapt the appliance to the height of the row of kitchen units, a suitable top cupboard can be fitted above the appliance ①.

For ventilation and air extraction, an exhaust air shaft at least 50 mm deep must be provided on the rear of the top cupboard over the entire width of the cupboard. The ventilation cross-section below the ceiling of the room should be at least 300 cm<sup>2</sup>. Generally, the bigger the cross section, the more economically the appliance operates.

- When integrating with standard kitchen units (depth max. 580 mm) and decor panels of up to max. 2 mm thick, the appliance can be installed directly next to the kitchen unit. The door of the appliance protrudes beyond the front of the kitchen unit 34 mm at the side and 51 mm in the centre of the appliance. This allows it to be opened and closed easily.
- When installing the appliance next to a wall ④, a distance on the hinge side of min. 36 mm is required between the appliance and the wall (handle projection with door open).
  - ① Top cupboard
  - ② Refrigerator/freezer
  - ③ Wall of kitchen units
  - ④ Wall

## Note on fitting decor panel\*

(with white appliances of height H = 1806 and 1982 mm)  
With decor panel and decor frame, you can adapt the appliance to the front of the kitchen units or contrast with them. The decor panels can be obtained from your kitchen furniture supplier. The decor frames can be retrofitted from your kitchen furniture supplier.

If you wish to fit the decor panel yourself, you require a drill or cordless screwdriver to pre-drill the retaining holes. The door handles are to be replaced by the rigid handles included in the decor frame retrofit set. For further assembly instructions and dimensions, please see the assembly instructions included in the retrofit set.

The manufacturer is continually working on the continuous improvement of all types and models. We therefore hope for your understanding that we reserve the right to alter design, equipment and technology without notice.

